

Suggested Power Unit Position

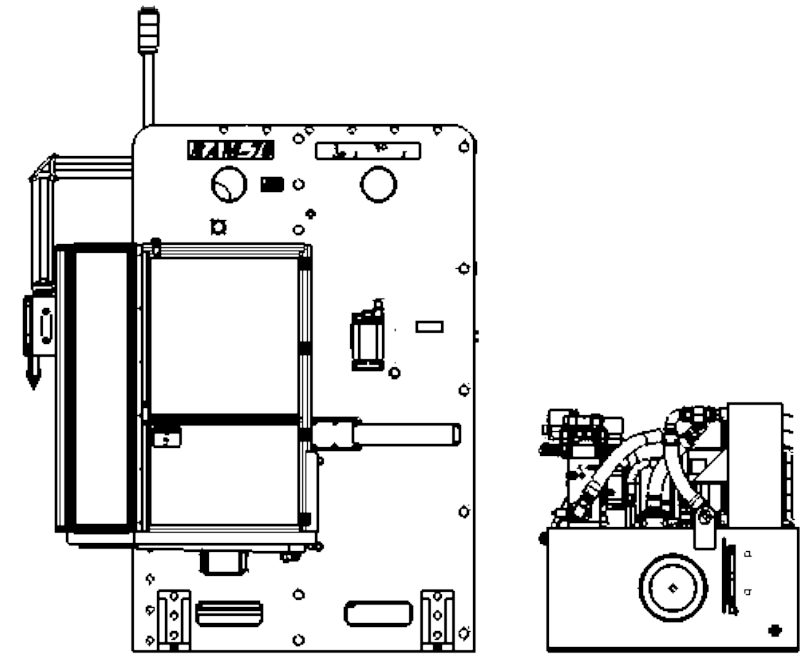
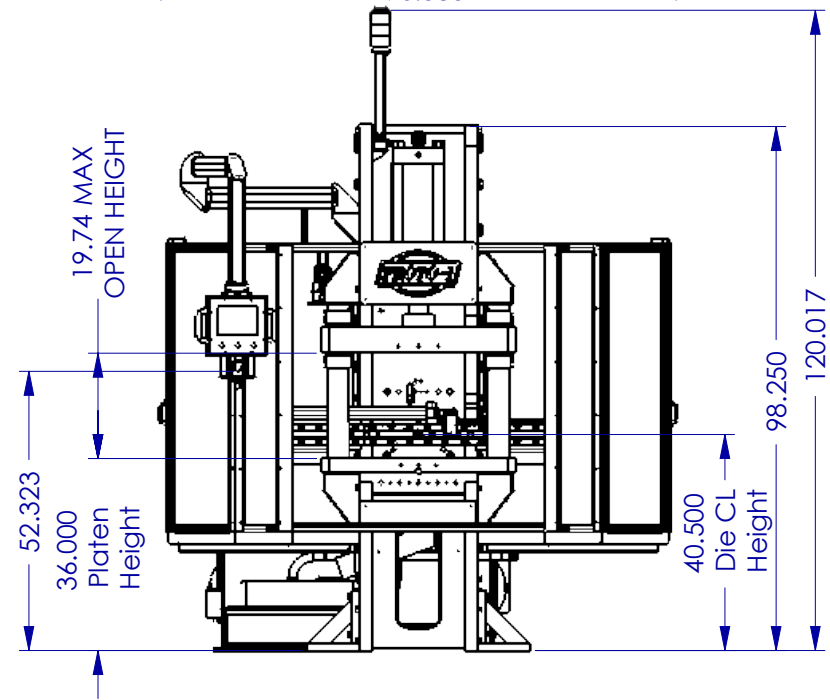
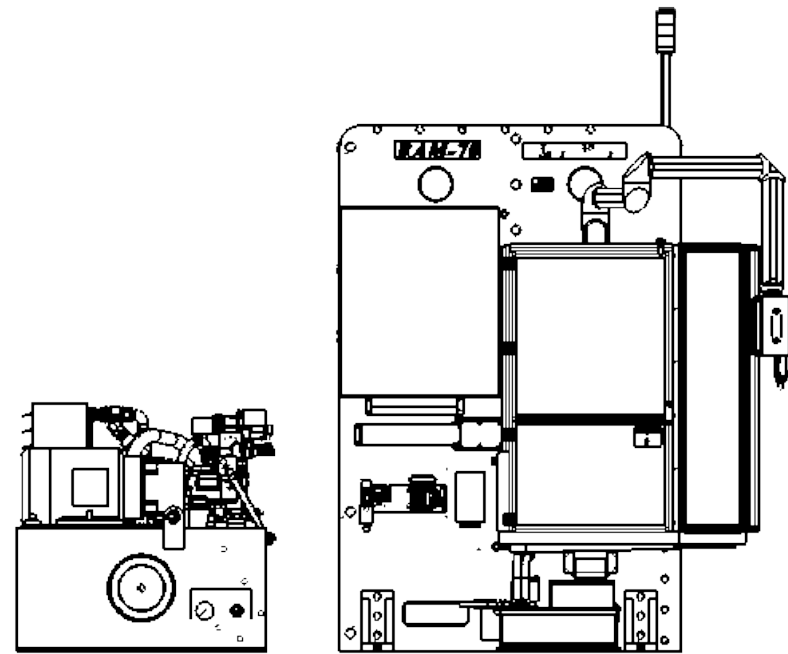
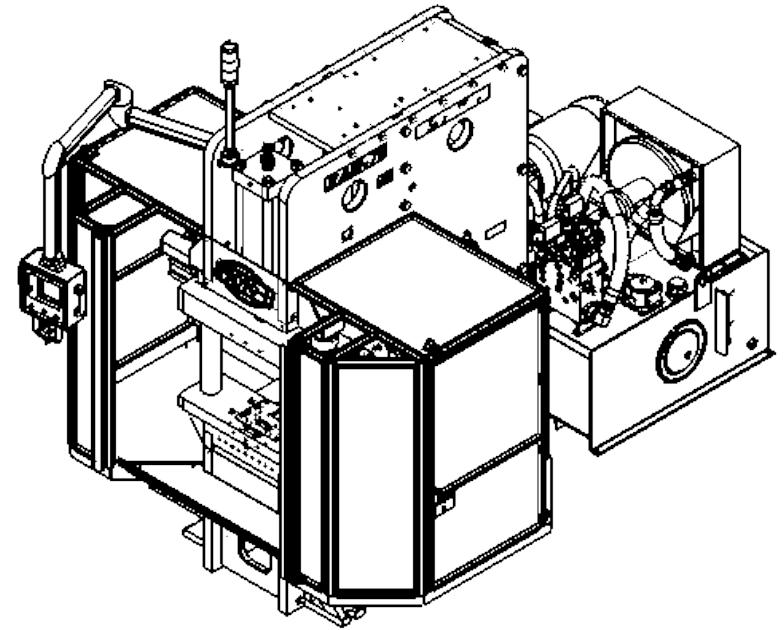
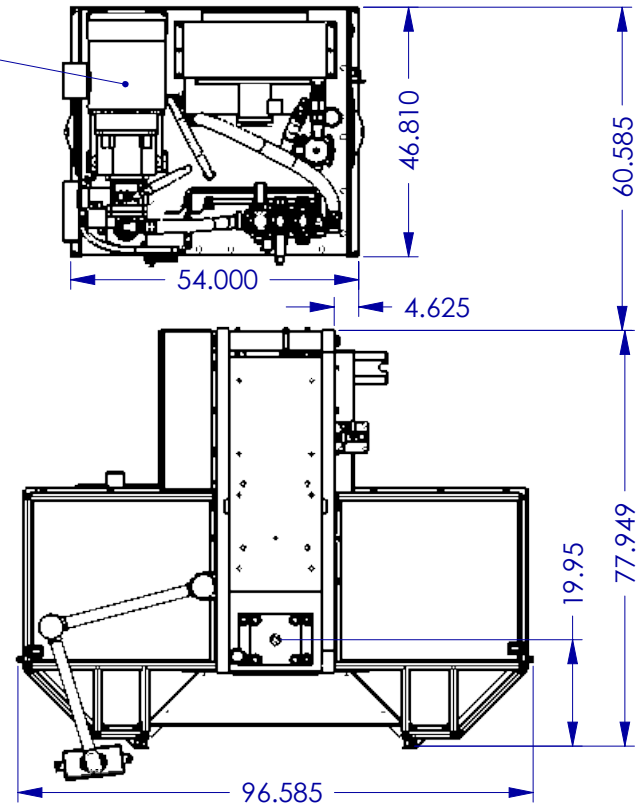

PRELIMINARY

NOTE:

PROTO - 1
Manufacturing L. L. C.
Winneconne WI.

THIS DRAWING CONTAINS PROPRIETARY INFORMATION WHICH SHALL NOT BE PUBLISHED, REPRODUCED, COPIED, OR FURTHER DISCLOSED WITHOUT PRIOR APPROVAL OF PROTO-1 MANUFACTURING L. L. C.

70 Ton Ram Machine Machine Assembly - Version "F" Main Assembly		THIRD ANGLE PROJECTION
DRAWN BY:	MWM	12/3/2010
APPROVED BY:		
SCALE:	1:36	
DWG. NO.	RAM70F-MAIN	
SHEET 2 OF 2	Est. Weight: 13144 Lbs.	
UNLESS OTHERWISE SPECIFIED 0.XXXX ±.001" 0.XX ±.015" 0.XXX ±.005" 0.X ±.030" ANGULAR DIM: ±.5 Deg. SURFACE FINISH: 125 BREAK ALL SHARP EDGES ENGRAVE DRAWING NO.		ISSUE 05